

The Wave Reading™

Instruction Manual

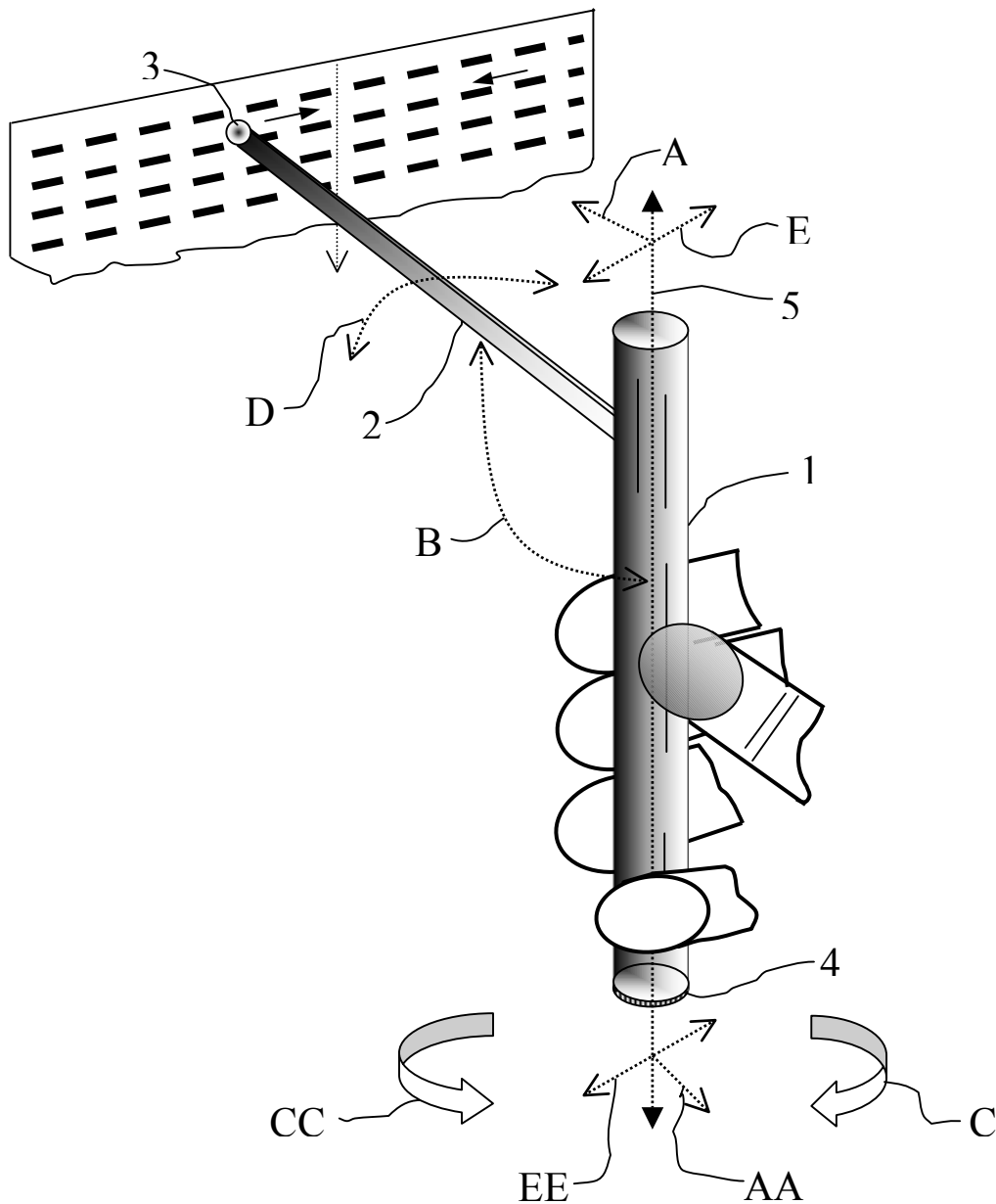

Welcome to Wave Reading™!

What is Wave Reading?

Wave Reading™ is a newly patented method of both general reading and speed reading that utilizes a twistable pointer called a “Wave tool” to *wave* beneath text lines. The purpose of the Wave tool is to induce your eyes to move in a faster and smoother manner to read successive lines of text more rapidly by following the tip of a twistable, shuttling pointer. An example of a Wave tool in use is shown in the cover diagram. The twistable pointer is alternately used either for a continuous motion induction reading method or for a widened-glance reading method. The twistable reading pointer can either be used as a training means or as a continuous use device for faster and more accurate reading. The device is simple to understand and to use, and quickly allows you to increase your reading speed!

A Free Wave Tool!

Although it would be illegal for you to make and sell Wave tools for a profit, you can easily make a *free* Wave tool for your own personal use by simply inserting one end of a 4 to 5 inch (10.16-12.7 cm) drink or coffee stirrer (or straw or thin stick or whatever you choose to use) through the compression clip of an ordinary ballpoint pen.

Angle the stirrer-pointer slightly upward as shown in the back cover diagram. The compression of the clip will maintain the pointer angle. When the lower portion of the pen barrel is then twisted back and forth between your thumb and fingers the upwardly angled pointer tip will move through a quarter-circle and can be easily used to underscore text lines. The moving (or *shuttling*) pointer tip then guides your eyes at a rapid pace with minimal effort.

The primary advantages to using the Wave tool to read is that the tool smoothes out eye movement and makes it more comfortable to read. It also induces your eyes to increase the rate at which they move across a page and allows you to quickly alter your speed reading rhythms and to stop and go with minimal effort. The Wave tool provides an almost effortless physical counterpart to your mental activity to keep your motor system happy while your mind races on through the reading process. With patience in the practice, you will soon understand how amazing Wave Reading™ can be!

It is our hope that we will soon be able to license our patent for the manufacture of inexpensive Wave tools associated with writing instruments, and as well to offer an inexpensive plastic hinged-pointer, clip-on Wave tool to fit an average sized pen barrel. A clip-on pointer for a pen would have a fold-down pointer that would rest parallel to the pen barrel and allow you to easily carry the tool with you in your pocket. Hopefully such ReadWrite tools will be the Wave of the future!

As you learn to use the Wave tool and improve your reading skills, you will be both witnessing and being a part of a reading revolution in the making. As you refer Wave Reading™ to your friends you will be helping to change and improve the way everyone reads!

Thank you for Requesting a Free Wave Reading™ Instruction Manual!

The Wave Reading™ Instruction Manual

A Quick Guide to the Primary Wave Reading Method

Two reading training methods will be explained in this Instruction Manual. One is called a *continuous motion induction* method, and the other is called a *sequential glance capturing* method. Both training methods rely on the use of a twistable reading pointer called a *Wave tool*.

The primary Wave training method utilizes the Wave tool to train your eyes to move at an even, comfortable rate to underscore the lines you are reading. You could use an ordinary pointer to achieve the same results, but the Wave tool is more effective and easier to use. The methods explained here presume that you can *sight read*, that is, that you have an extensive vocabulary and that you can quickly recognize the majority of ordinary words when they are applied in varying contexts. If you have not yet learned to do that, the Wave methods will not help you to either read faster or better.

You really do not need this Instruction Manual to understand how to use the Wave reading tool to learn to read faster. If you look at the pictures included in the manual, they should give you the general idea and you can take it from there by trial and error.

So why then is there a lengthy manual included with the tool?

The purpose of this Instruction Manual is to offer you helpful, and hopefully, motivational information about the reading process, as well as various insights and techniques on the use of the Wave reading tool so that you may become a *better* reader as well as a faster reader.

The Wave tool is not a complex device. Once you understand the basic grasping methods and the various possible use positions of the tool, you simply twist it back and forth between your thumb and fingers and use the pointer arm tip to guide your eye motion as you read, just as you would with an ordinary pointer.

If the Wave tool is not operating for you as you think it should, you can always read the manual for further information and advice.

Reading Faster by Training with a Pointer

When you first learn to read, you realize you can only interpret the words in a line if you pause over each word for a period long enough to process its meaning in context. As your word recognition skills increase, you begin to nearly instantaneously recognize, or sight read familiar words and so read faster. The issue then becomes how fast can you sight read without losing the words in a blur? Can you read with a continuous eye sweeping motion?

It has been known for over a century that no useful information is received by the mind when the eyes are in continuous motion. Experiments have shown that during reading, very rapid brief eye movements called *saccades* are followed by slightly longer periods of fixation during which the actual perception of the words occurs. As we gradually learn to sight read, we typically attempt to increase our eye sweep rate to an even rate which may seem continuous, but is actually discontinuous as we make our saccades and interpretations along the linear path of a text line. As we read, our eye sweeps are usually progressively forward from left to right across the line. But at times when there is a misread, missed or misunderstood word or words, we make

The Wave Reading™ Instruction Manual

corrective regressive rearward eye motions during which we reread words in the text. If we have frequent regressive eye motions our reading tends to slow down considerably.

Another problem in the physical mechanics of reading is maintaining the *continuity* of reading both between successive lines and between sentence parts and completed sentences. Often there are longer pauses than necessary occurring between lines and as we pass over punctuation markers. These unrequired pauses tend to disrupt the continuity of our understanding of the flow of thoughts in the material.

Since it is not possible to read with a continuous motion, the question then becomes, how do you train yourself to make your saccades and pauses over words and punctuation markers as brief as possible, and your regressive eye motions as infrequent as possible as your eyes sweep across a line? Also, how do you learn to make more rapid and accurate alignments between lines to maintain continuity?

The answers are actually quite simple: You first learn to properly operate a *reading pointer*, and then use the pointer to train your eye motions.

Learning to read faster and more accurately can be remarkably enhanced by using an ordinary pointer such as a fingertip, or pen, or pencil, to overcome most eye motion problems associated with the mental pausing process and with *unnecessary* regressive rereading. A properly operated pointer can do more than simply guide eye motion along your line of sight—a properly operated pointer will *induce* your eyes to move at the same rate the pointer tip is moving. This motion induction process significantly reduces the time that your eyes stay in any one radial angular position along the sweep line. A pointer thus induces your eye motion to become more or less continuous even though your eyes are discontinuously processing each word and punctuation marker they briefly view. Using a pointer also enables your eyes to more accurately align with and focus upon the next successive line to be read.

What few readers ever truly realize is that it is in fact possible to comfortably read and adequately process all the words in a line using saccades and pauses that occur in terms of *milliseconds*. Using a pointer does not stop the pausing process. What it does instead is to reduce the pausing process to a rapid and unseen flicker, shutter or *pulse pause* effect as the eyes swiftly pass over the words during their attempt at continuous motion. Using a pointer enhances the evenness, rate, and apparent continuity of the words being read as though they were *flowing* past your view just above the pointer tip.

Using a pointer thus urges your mind to accept briefer pauses per word, but only to a very real limit. If the pointer is moving too fast you will only see a blur of words (because the eyes are in continuous motion) in which you pick out (pause upon) a key word here or there. In other words, you will be aimlessly scanning or skimming through the text lines. Skimming causes a large amount of information to be missed. If you are told to only skim a text, you can *seem to read* as fast as speed readers seem to do, but you will also fail to take in the details of the material.

If you are reading just to get the general ideas in your material, skim reading using a pointer is not an issue. But using a pointer at an excessively rapid pace does not allow you to truly capture each word and punctuation marker in a text line for its overall contribution to the contextual meaning of a sentence. Often critical structural words are lost in the blur and it becomes necessary to frequently regress to reread a passage to see the actual connection between

The Wave Reading™ Instruction Manual

one word grouping and another. Conversely, if the pointer is moving too slowly, pauses become longer and reading becomes awkward and time consuming.

There is, however, an intermediately rapid, but *comfortable* back and forth swing rate, or *shuttling* rate for you to use a pointer. A rate which is not too slow and not excessively fast, during which it is possible for you to use a common pointer to quickly capture the meaning of all the words you are reading. Moreover, a pointer will also assist you in avoiding *unrequired* regressive eye movements by generally maintaining a constantly progressive sweep beneath the words to be read. By the time your mind decides to reread a word or a passage, it has usually seen the sentence in its entirety and filled in the blanks or corrected its errors.

During reading, when you sweep your eyes left to right across a line of text and rapidly identify the words in the line, what you are doing is inducing your mind to rapidly generate a flowing pattern of short duration *memory traces* of the meaning of the words and punctuation markers you have seen and recognized in the line. Using a pointer helps to induce these memory traces and patterns to properly generate in an even and immediate manner so that they will more effectively develop and integrate into appropriate trace memory patterns. The expanding number of trace pattern arrays and their integration with one another in your mind are then the immediate meaning you get from what you have read.

To perform accurate processing during reading, there must first be accurate sight recognition of the words and punctuation markers in the line being read. Secondly, you should accept that during the brief time that you read a line, it is not fully processed if a sentence begun in the line continues to the next line. As your eyes move on their return sweep to their alignment position with the next line, the previous line is still being retained and processed by your brain. Each line is thus processed in terms of what preceded it as meaning and what will follow it as meaning.

When you do not maintain continuity during your sweeps of the pointer (and thus between completed memory trace arrays) for this continuous processing principle to operate, it will *not* operate. The lines will be seen and heard, but the processing will not occur which allows the initial short term memory trace images and feelings of the lines to fully pass into the integration phase. To provide yourself with the overall meaning of the lines being read with the other lines read and yet to be read, you need to maintain continuity in your eye sweeps to allow the integrational processing to occur.

Again, you must find *your own comfort rate*, which is not too fast and not too slow in order to properly continuously integrate the memory traces from one line with another. If the trace pattern does not carry a clear reproduction of the details of the line, or is not processed as just explained, the meaning of the words may remain unclear or as though they were not read.

The general limitations of your brain's initial short term memory buffers (storage areas) set a limit on the rate at which you can successfully read an entire line at a high rate. Your reading rate cannot exceed your mental capacity to process information. You can only attempt to determine what *your* highest comfortable processing rate actually is. What is to be determined then is: How fast can you generate accurate word traces, and then continuously integrate these to effectively interpret a text line for its contributive meaning to the overall text? The eventual fastest rate that you reach is your highest comfort rate for processing and depends on your own unique and individual mental processing abilities, reading strategies and overall language abilities.

The Wave Reading™ Instruction Manual

Thus when using a pointer to train your eyes to move at a median comfortable pace, it is possible to avoid skipping over words and punctuation markers (skimming or scanning) and actually begin to appreciate the overall enjoyment that comes from reading quickly, clearly and meaningfully. Over time, with sufficient practice, you can use your fingertip or an ordinary pointer to train your eyes to move in a straighter line with briefer eye fixations, and as well to make swift and accurate return sweeps to begin the procedure again. And if you learn the procedure well, you will usually be able to train yourself to read faster and more comfortably even without the pointer. Or you may continue to use a pointer, as you need it.

So why then doesn't everyone use a fingertip or a common pointer and find his or her comfortable rate for faster and clearer reading? Because for most readers moving their fingertip repeatedly across many lines of text, or using a common pointer to do the same thing, is a tedious and tiring task. And because, regrettably, depending upon the individual reader, it requires several hours or days to several weeks of pointer training to induce the reluctant mind to continuously interpret words at a rate which is fast, clear, and comfortable. It's just that simple.

In a common pointer such as shown in Fig. 1 of the enclosed diagrams (located in the end pages of the Instruction Manual), all control over the pointer tip is in the hand and fingers grasping the control end. Since a common pointer is operated by using wrist and/or arm movements in a continuous, tiresome swinging movement, many readers abandon the pointer long before they have realized the benefits associated with training their eyes and mind to read using a pointer method.

The obvious problem then is not with the pointer method. It is with the pointer itself. What is needed is a reading pointer which is easier to use.

The Primary Wave Reading Method

A Pointer With a New Twist

As shown in Fig. 2, the Wave Reading Methods utilize an innovative type of *twistable reading tool* with an angleable pointer to facilitate reading training. A Wave reading tool, or *Wave tool*, is physically and operationally distinct from a common pointer in that it consists of a twistable rod called a *control member* (1) and an adjustable, pivotally connected, miniaturized *pointer arm* (2) with a *pointer tip* (3). As the lower portion or *control surface* of the control member is twisted back and forth between your thumb and fingers, the pointer arm is forced to shuttle through a 90° arc back and forth across a page. The shuttling pointer tip can then be used in the manner of a common pointer to trace an imaginary line for your eyes to follow below a line of text. Your eyes are then naturally *induced* to follow the pointer motion and move straight across the text line in a more continuous and efficient way.

If you choose to utilize the Wave Reading Methods, you will find that its various techniques operate using the same basic reading principles that all realistic faster reading methods must use, that is, near continuous eye motion induction, extended linear perception, fewer and briefer eye pauses, avoidance of unrequired regressions, and continuity of line-to-line reading. But in the practice of these various techniques you will also find that the Wave methods take a somewhat different approach as to how these standard principles will be applied.

The Wave Reading™ Instruction Manual

Grasping the Wave Tool

In Fig. 2, a Wave tool is shown being held upright and in use underscoring a set of symbolic dashed text lines. Each dash is then representative of one or more words in a typical text line. A set of linear spaces in-between the set of text lines are respectively intended to exemplify the open, intervening spaces between parallel text lines. The pointer arm is shown targeted on an upward angle toward a linear space below a text line being read.

As shown in Fig. 2, the Wave tool is typically held at the lower control surface of the control member by a thumb, an index finger, a middle finger, a ring finger, and a little finger. Note that the little finger in the drawing is on the thumb side of the control surface to better stabilize your grasp when the control surface is being twisted back and forth. Your little finger may also be placed on the finger side of the tool to stabilize the grasp.

Your thumb and fingers so positioned then grasp the control surface in a slight, but comfortable, squeezing manner and twist against the control surface back and forth to shuttle the pointer arm. If you are left-handed, then the depictions and explanation of the grasp of the control surface of the control member would be reversed. Whichever hand you use will be referred to as your *steering hand*. The grasping method shown in Fig. 2 can be used whether the tool is being used upright, inverted, or horizontally, as will be explained.

Basic Upright Operation of the Wave Tool

When you have adjusted the Wave tool pointer arm to the upward position shown in Fig. 2, please grasp the control member as described above. The control member is then twisted back and forth in the following manner. As shown in Fig. 2, the initial twist is done in a clockwise rotation (C) up to 45°, and then in a counterclockwise rotation (CC) up to 45° to shuttle less than a full 90° (D). The correct left-to-right movement of the pointer tip relies on a smooth, continuous, clockwise, rolling motion of the control member between the thumb and fingers followed by an immediate reversal of pointer direction. The counterclockwise, right-to-left return sweep of the pointer tip is done in a smooth, but slightly more rapid manner to an alignment position below the first word in the next lower text line, after which the pointer sweep direction is immediately reversed again to a left-to-right sweep.

The left to right sweeping, or *waving* motion that you make with the Wave tool is called a *trace wave*. The right to left waving motion that you make with the tool is called a *return wave*. The zigzag back and forth pointer waving motions of successive trace waves and return waves is called *shuttling*. Shuttling is best achieved as the Wave tool is smoothly twisted back and forth and progressively lowered down the successive text lines at a comfortable reading rate. As you practice shuttling the Wave tool beneath the successive lines of text in this manual, you will realize that although the pointer tip traces out a curve as it swings on the pointer arm, your eyes will naturally focus *straight past* the moving pointer tip and so focus only on the words and punctuation markers in the text. Your eyes are naturally induced to follow the pointer tip movement without actually looking at the pointer. It is important then that you do not focus on the moving pointer tip, but only on the words and markers over and beyond the moving tip. When you shuttle the pointer tip lengthwise side to side beneath the successive text lines, your objective is to mentally weave the sight read words together to form a continuous thread of ideas that will progressively develop into a full tapestry of meaning from the text.

The Wave Reading™ Instruction Manual

Unlike a common pointer, the Wave tool will allow you to make smooth and swift continuous sweeps left-to-right, and immediate return sweeps right-to-left with minimal effort. As well, the pointer tip can be easily and quickly stopped wherever you choose, and easily guided through the successive lines of text. In the primary Wave method, the shuttling pointer is used *to induce a more continuous eye motion across an entire line of text* irrespective of the angle of the reading material or your current line of sight toward the text lines.

Tilt and Wobble Effects

Several simultaneous forms of motion are occurring when you read text lines while using the Wave tool as a guiding and motion inducing means. When the control member is being twisted in alternate directions to cause the pointer arm tip to shuttle back and forth, the tool is also simultaneously being moved longitudinally down the page of text lines by natural arm motions. As these motions are occurring, the control member may be held parallel to the flat plane of the text lines, or may be used *while being continuously tilted forward* in order to minimize downward arm movement (Fig. 2, 5 at A, AA). Tilting is done by bending the wrist and tipping the control member forward *as you are shuttling the pointer tip*. Tilting can help you to keep the zigzag, downward-moving process of the shuttling pointer tip aligned with the successive order of the text lines.

Tilting the tool forward also allows you to better see over the top end of the control member under different reading circumstances, for example, when you are reading text on a computer monitor. As the control member is tilted progressively forward from a vertical position as your downward arm motion progresses down the page, the arc that the pointer tip sweeps out (D) progressively changes from an upwardly disposed arc, through a circular arc, to a downwardly disposed arc. Your goal is thus to utilize pointer arm angles and control member tilt angles that maximize the *flattening* of the arc toward a straight line. This will provide you with the straightest possible path for the pointer tip beneath the text line.

There are several ways in which you can achieve a flatter arc and so effect a straighter trace line for the pointer tip below a longer span of words. As you wave and tilt the pointer tip across a longer text line, you may also tip the device to the right by slightly twisting your forearm, causing the pointer arm to cyclically side-tilt, or cyclically *wobble* transversely on its axis (5 at E and EE) from the lower pivot point of the ring and little fingers. Or you may simply swing your forearm laterally back and forth from the elbow as you are twisting the control member. When you read short text lines arranged in columns such as are usually found in newspapers and magazines, rather than twisting the Wave tool, try just wobbling (side-tilting) it to cause the pointer to pass under the text lines with less effort.

Initial Orientation Exercises

In Fig. 2, the tool is shown being held in an upright position with the pointer arm in an upright angle. The tool may also be usefully held in a variety of other positions with different pointer angles and operate just as effectively, as will be later discussed. For the moment it is best if you maintain the Wave tool in an upright position until you are better orientated to its general use. In this section you will be learning how to train your eyes to effectively use the upright Wave tool to underscore text lines, that is, to properly and quickly perform trace waves beneath

The Wave Reading™ Instruction Manual

the words in successive lines, and as well how to properly perform return waves. The exercises will not be labeled as such. Just use the tool as you understand its use thus far, and practice doing what the text is suggesting that you might try as a further technique of use.

Please place these instructions in an upright position in front of you. Then grasp the Wave tool in an upright position with your steering hand. Position the pointer at an upward angle as shown in Fig. 2. Once you become more familiar with the tool when it is used in this basic upright position, it will be easier to use the tool when it is inverted or otherwise positioned. Please use the lines in the following paragraphs as a series of test lines. As you proceed here, please try and use the tool by twisting it back and forth between your thumb and fingers. Use the pointer arm tip to guide your eye motion as you read, just as you would with an ordinary pointer.

Try to be patient with yourself when you begin the “twist to read” process. It takes time to adjust your hand and eye coordination as well as your mind to the procedures involved. Begin slowly and increase your speed gradually lest you find yourself just twirling the tool and shuttling the pointer tip back and forth without actually reading the words that your eyes are seeing. Again, whenever you are not comfortable with the increased rate at which you are viewing the words, *slow down, or pause and start again.*

During the explanation of the following techniques, try to allow yourself to rapidly follow the directives of the punctuation markers in the lines you read, or to generate your own punctuation markers as you rapidly takes in the phrases and clauses in the lines being read—but without *physically hesitating* over each marker. The only actual physical hesitations you should experience in the reading of any two successive lines that you have read and understood are the brief instants during which the metronome-like pointer sweeps change direction from a left to right trace wave to a right to left return wave and then resume a left to right trace wave.

Try to maintain a sense of *continuity* between the meaning of what you have just read in one line and the meaning developing in what you are now reading as the next line in the text. If you feel you are losing this sense of continuity, slow down or pause and start up again to attempt to restore a comfortable reading rhythm.

As you use the Wave tool, try to make a smooth and continuous left to right trace wave beneath the line you wish to read. And then make an equally smooth, but *slightly* faster return wave to the alignment point of the next sweep, that is, beneath the first word in the next line. The rate that you use to swing the pointer left to right and then right to left will ideally fall within two undesirable regions: the excessive rate where the words are not actually read, and the halting rate of word to word pointing.

If you *snap* the pointer back to its next alignment point in an attempt to read faster, the opposite effect may occur because you will tend to overshoot the alignment point. Also, the physical motion of your eyes during the return sweep will try to match the rate of the snap-returned pointer tip and you will likely lose focus and continuity as they do so.

Your objective in using the Wave method should be to use a left to right swing rate and a return sweep time that is personally comfortable for the *immediate* level of difficulty of the material you are reading. If this means to occasionally slow the pointer or actually stop the pointer to think about what you are reading, *then do so.* And if you do not understand a line or lines you have read, *reread them.* If you shuttle too rapidly with difficult material, the meaning in the words will not be fully interpreted.

The Wave Reading™ Instruction Manual

Conversely, if you *always* shuttle slowly, you will lose the continuity required to quickly integrate the line being read with the next line to be read. Experiment constantly to find shuttling rates that work effectively as you pass through different levels of difficulty within your reading material. The rate chosen to be used should allow you sufficient time to take in and *listen* to all the words in the line before moving to the next left to right swing over the next successive line. If you do not *hear* a line correctly, i.e. gather its meaning, wave over it again to *listen again* before going on.

Do not be discouraged by the thought of rereading entire blocks of material. If you were distracted and did not understand what you read, admit this to yourself and read the material again. Whereas this is a frustrating and time consuming proposition when you read slowly, when you read quickly it is not an issue.

When you can read faster you will find that purposely reading slower does not always increase focus and concentration. Instead, it often invites the mind to wander. Since you are capable of thinking very fast, if you are reading slowly your mind will tend to introduce random thoughts at the same time you are trying to read. When you allow your personal worries or random thoughts to intrude on your reading, it is no different then when you are being continuously interrupted and distracted by another person. As your reading rate increases and more of your natural capacity and focused attention is being used, instead of trying to consider other things while reading, simply stop reading, take care of what needs to be considered, and then continue with your reading. It often helps to keep a pen and writing pad on hand when you read so that you can jot down the things that your mind is wandering to so you can take care of them later without having to keep them in your thought stream, e.g. things to do or to later recall when your reading session is paused or over.

Try to twist the Wave tool smoothly at a steady and even pace left to right and then right to left beneath the successive text lines while attempting to place the tool's pointer tip generally below the lines. As you practice this procedure your eyes should be attempting to follow the pointer tip *without actually looking at it*. You should be looking *past* the moving pointer tip and seeing the words *flowing* within your linear view as though the pointer tip were fixed in your moving line of sight and the words themselves were streaming past the tip.

Try to maintain your eye movements so that they always align with the position of the pointer tip. Your eye focus should arrive at the beginning of the first word in the next line at the same time that the pointer tip reaches below that point. Your eye motion should then accelerate left to right as the pointer tip accelerates. If the next text line is a line with one or a few words, for example, where brief dialogue from different speakers is being presented, simply pause the pointer in mid-air and capture the words in a *widened glance*. Then drop the pointer tip to the next line alignment position and resume your original tempo in the shuttling process.

For a brief moment, try the following experiment to better realize how much of your reading is actually being done on a subconscious level of perpetual recognition. Briefly allow yourself to *consciously sense the white spaces* as they speed past your view in the word stream. When you have sensed the white spaces but once, you will realize that they are as much a part of the reading process as the actual words and the punctuation markers. The white spaces along with the punctuation markers are *subconscious command symbols* to the brain which direct your mind to properly interpret the line within the context established to that point in the material.

The Wave Reading™ Instruction Manual

When you train to rapidly read with a pointer, the punctuation markers and the white spaces between words are almost unseen and processed at a level just below your conscious recognition of the words in the text lines. The rapid induction motion of the pointer tip generates an *unseen* rapid pulsing effect which tells the mind very quickly both where the line's individual words start and end and how to best process the line in terms of the current punctuation markers.

Tripping over words is often due to not rapidly, subconsciously accepting spaces as the actual pause markers in the word flow. Briefly consciously realizing that they the actual pause markers will help clarify for your subconscious mind that in addition to processing all the words and punctuation that you are seeing, that you want to always interpret the white spaces as tiny, but not inconsequential *speed bumps* between the words. You will not actually ever be consciously focusing on the white spaces, but merely realizing their necessary presence in relation to the words and punctuation markers in the lines you read.

Improving Your Sight Reading by Sight Listening

When we first learn to read as children, we struggle through an active process where our eyes are moving haphazardly and our inner mind is speaking haltingly while we are intent upon gathering information from a text. We strive to speak the words within ourselves and listen to our inner voice in order to actively pursue the meaning of the words.

As we gain experience with reading and become more proficient at the task, we do not usually struggle to read. But we still tend to listen to ourselves speaking the words within our heads. So there is always this extra step in the transformation process between reading words for information and actually obtaining information from the words.

To hasten the reading process by willfully removing this extra step—the conversion of what we see into a self-spoken word flow—we need the option of a different reading procedure. An option that we can instantly turn on or off as we choose so that we can either be the reader-speaker of the words and the listener to the words, or *just be the listener*.

The optional procedure is to *allow* the direct transposition of print information into *sound* heard in your mind.

This different reading mechanism can be called *sight listening*. Sight listening means to sight read at an *accelerated listening rate*, at a rate far faster than anyone can speak, but slow in comparison to what we are actually capable of hearing and understanding within the mind. Sight listening, or speed listening allows an immediate playback of the printed words analogous to the way in which a laser plays back sound from a compact disc or a DVD.

As you read the successive lines, *listen within quickly, clearly and with feeling*. Quickly hear the necessary expression that the writer would use if he or she were speaking to captivate an audience. You *are* the audience. You *are* the audience member who is hearing the writer speak to you almost as though by mental telepathy from the printed page. Regard the sight listening activity as a rapidly moving performance which you are quickly watching unfold. Encourage yourself to think of the rapid sight-listening experience as though you were attending an accelerated dramatic play or a cinematic presentation moving very quickly, but never so quickly that they are beyond your ability to understand the developing events as they occur. Focus on watching and listening to the sights, sounds and conversations of a drama, or a lecturer in his discourses, or any information that you hear, as though you were in a surrealistic place. A place

The Wave Reading™ Instruction Manual

where you can hear a writer's thoughts at virtually whatever rate you acquire the ability to listen. A place where you are neither constrained to read faster than the spoken word, nor limited to it.

Read the lines evenly and only *mentally sense* any punctuation and spaces you pass over without slowing down the pointer motion. To read properly with the Wave pointer you need to maintain your sense of continuity within the material by gathering together the meaning in a series of rapidly assembled complete lines. A sentence begun in one line may continue to the next line, but as you successively read complete lines while maintaining the continuity of their meaning, your innate reading abilities will determine where a sentence ends and a new one begins. The mental capability for this reading process is already built into your mind and will occur naturally, but at an accelerated rate. You do not have to physically pause for sentence end markers. When you read the lines successively, your mental pauses for the sentences and paragraphs will take care of themselves, i.e. your mental pauses will naturally allow the successive lines to integrate into meaning for you. If you are losing the continuity of meaning, slow down and physically pause more frequently to clarify what you think you have understood as the *heard* meaning of the words.

Shuttle the pointer quickly and smoothly left to right, and right to left beneath the text lines while attempting to rapidly sight read and rapidly *hear* the line. Reading in this way induces a rapidly perceptible *word flow* or *word stream*. You should be hearing the writer speaking as an inner voice speaking the words to you *very fast*. As you hear this quickly speaking inner voice, you should *try to listen to it at the same rate it is speaking*. What you are then doing is *learning to listen faster*.

When you listen faster, you should not think of yourself as the *speaker* of the words. Think of yourself as the *listener*. When you first learn to rapidly listen to the generated thought stream—the thoughts of the author of the words—it is a conscious process. But as you continue to rapidly listen, the process becomes routine as you realize you are not actually *saying* the words, but only *listening to them at an accelerated rate*. As you continuously move through the lines of text, what you are doing is more fully processing what you have *heard* at an accelerated rate.

In time, with practice, to another watching you read, it may seem as though you are simply shuttling the pointer back and forth across the text lines. But you will know in your mind that you are actually rapidly listening to the text and understanding it as you read.

When you read, try to *expressively* seek a mental image and feeling reproduction of the meaning of the words in the text. To sight read music you must quickly hear the music in your mind. But whereas sight reading music at a fast rate will lead to a failure to duplicate the score as written, faster hearing of a spoken text will lead to greater comprehension—if you *actually hear and recognize each word in the increased word flow rate*.

To rapidly sight read words you must quickly hear the words in your mind. When it is otherwise you are not reproducing the meaning of the text in your mind. You are simply skipping over words to sight read target words. When you sight read during a skimming processing of a text, you can think and be aware *without* a vocal stream of words. But that is not what you want to do when you read using the primary Wave method. You want to *hear* the words. But you want to hear the words at a much faster rate than normal, and then process and interpret them at this faster rate.

The Wave Reading™ Instruction Manual

If you are truly trying to skim over the words looking for target key words, rather than trying to hear and interpret the text directly, then these key words are the only words you should allow yourself to hear. You can skim or scan at a far greater rate than you can read by listening faster, but you will not be interpreting the text as written except when you hit your target words and then listen to the section of the material which applies to the targeted words.

To reiterate and expand upon these ideas, sight reading by sight listening using the Wave tool is achieved by the immediate recognition and hearing of the words which are being induced to flow at a high rate. Sight reading at this faster listening rate is also partially achieved by the immediate recognition and expressive listening reproduction of the outlines of recurring word patterns, or sentence, clause and phrase types, as well as grammatical relationships and other contextual clues, punctuation, and so on. Often the subtly intended meanings in a word flow are hidden in the nuances of an audible expression of the text being read. This is *why* you listen with *expressive feeling* to what you read.

Various reading courses teach that sight reading also means not hearing words in your mind. But to derive an accurate meaning from words, they need to be *expressively heard* in the mind so that they may be properly processed as they have appeared in context. Skipping over (not hearing) the structure words, like a, the, and, or, etc., or failing to add grammatical emphasis and tone to what you read is akin to what happens when you are listening to a broken conversation through the static of a bad phone connection: Meaning gets lost in the process. What is needed is to *develop the ability to hear words expressively streaming at a very fast rate*.

What is needed is not to *say* each word in a line, but to *hear* each word in the line at a faster rate. Speed or sight listening is distinct from rapid subvocalization in that you *do not* attempt to say the words you are seeing: However rapidly you can comfortably see and recognize the words, this is the rate at which you will *hear* them.

Think of yourself as being in the presence of the author of the words you are reading as though he or she were directly before you and speaking the text to you. What do you do when you are focused on listening to a speaker? You begin to imagine what the speaker is talking about. As sight reading becomes sight listening you should not only hear the words in the word stream you are reading. You should see the writer's thoughts flowing as imagery and feelings generated in the imagination of your mind.

When you listen to someone speak you do not pronounce his or her words as they say them: They say the words. *You just listen*. Similarly, when you sight read to sight listen at an accelerated rate, you do not pronounce the words to which you are listening. *You just hear them*.

Try to hear the voices of the text as though they were coming from the author and/or his or her characters within the page itself, as though the reading material were being induced to speak its words directly into your inner mind.

Using a previous analogy, just as a laser passes over a rotating disc to produce images and sounds, your eyes should serve to elicit the meaning of the word data stream to which you are listening to effectively produce the inner sight and sound you perceive in the word stream.

To use the laser analogy in a slightly different context, try thinking of your mind as projecting a radial linear beam from its center in your line of sight of the words as they flow past your view. Like a sweeping radar beam reflecting left to right from successive linear targets, the radial line of focus is sounding out and imaging the words in pulsations which will become the

The Wave Reading™ Instruction Manual

completed continuing reflection, or trace image which your mind will retain and process when the beam momentarily disengages to make its return sweep.

When you fully experience rapid sight reading as accelerated sight listening, you will have clearly understood how truly different it is from ordinary reading. At first these new routines of reading may seem awkward to you, but as you continue to use the Wave tool, the words will begin to flow past your moving view and become a flowing thought stream. Initially concentrate on correctly applying the technique. Perception will follow, and later, comprehension will follow. As you continue to practice the primary Wave method, and progressively train your eye motion and mind to sight read and listen using the Wave tool, your saccade rate will increase and your pause times will naturally decrease as your mind begins to understand what you are trying to do and accommodates you by clearly hearing the lines faster.

Be patient with yourself. Go slowly at first and gradually build up speed. Eventually you will reach a rate that is both comfortable and meaningful for your personal limits of faster reading.

The primary advantages to using the Wave tool is that it will train you to read more quickly and more comfortably with a greater comprehension of what you have read, *but not immediately*. As earlier noted, it will take your mind several hours and up to several days or weeks of practice with the new method to adapt to the increased reading rate. Because this is so, it is not a good idea to immediately practice your new skills using difficult reading matter. Read easy novels and light magazine articles until you begin to feel that your mind has become accustomed to the idea that it can accept written material sight read and heard at a faster rate using the new method.

Once you have fully acquired the basic eye movement techniques involved in the use of the Wave tool, you may or may not need the tool to continue reading faster. If you read without the tool for long periods and find yourself losing the natural continuity of eye motion that the tool has taught you, the tool can be utilized to “jump start” your mind to regain the natural eye rhythms of faster reading. Or, if you prefer, the tool can be used continuously as a faster reading aid.

However you use the Wave tool, its induced motion sight listening method will always only be an *option*, and not the way to be used to read everything. You will know when it is preferable to use the speed listening method to read quickly, and when the level of difficulty of the material makes it preferable to read at a lesser rate or using a different tool method, as will later be discussed below.

Operating the Wave Tool in Diverse Positions

Reading material may be angled in several different ways relative to your line of sight. In Fig. 3, the larger top boxes A-D on the top exemplify the common positions of reading material, e.g., books, newspapers, magazines, legal briefs, work assignments and so forth, along with their typical lines of sight for a reader. Boxes A-C respectively show reading material being presented in a vertical position, and then in a typical 45° or inclined position, and then in a flat surface position, with respect to various frontal lines of sight. Box D exemplifies inclined reading material that is being viewed from a left and a right line of sight.

It is sometimes necessary to change the control member position and/or the pointer arm angle of the Wave tool to better accommodate these reading material angle and line of sight

The Wave Reading™ Instruction Manual

changes. However, the basic grasping method described earlier for the upright position of the control member equally applies when the Wave tool is used in an inverted or horizontal manner.

In the lower boxes 4-19 of Fig. 3, the tool is diagrammatically shown being held in a variety of upright and tilted positions and in a variety of inverted and tilted positions. The tool may be used in different positions, or by using a sequential combination of these positions, to better cope with varied orientations of reading material being read from altered lines of sight. As shown in Fig. 3A, the tool may also be effectively used in a horizontal manner.

As you read on through these orientation exercises, please experiment with the various control member and pointer angle positions indicated in boxes 4-19 to determine the tool settings that are the most effective and comfortable for your optional use.

Whether material is presented vertically, inclined, or flat, and whether the material is viewed from a head-on line of sight, or otherwise viewed from a left or right side position, there will always be one or more upright and/or inverted tool and pointer arm positions that will allow you to operate the Wave tool in an efficient manner.

When starting to read any material with the Wave tool, first consider the orientation of the text relative to your body position and your possible lines of sight. Is your steering arm to be placed to the front or to the side? Will an upright or inverted position for the control member more easily clear your immediate line of sight?

Will you be reading by moving your steering hand straight down the page? Or will you be tilting and/or wobbling the tool as you read? If you will be tilting the Wave tool during use, you will probably be sequentially utilizing various positions that appear in boxes 4-19 as your wrist is tilting gradually forward, e.g. 8, 9, 10, if the tool is upright, or 14, 13, 12, if inverted. Your steering arm's elbow will probably then be crooked to the side of the reading material and closing its angle somewhat as your steering hand moves progressively down the page, thus utilizing the tilt change to minimize your downward arm motion.

To effectively read a larger-order piece of reading material, such as a legal brief, which is laying in a flat position directly in front of you (as exemplified in the diagrammatic illustration of Fig. 3A), an upright or inverted underscoring tool position is typically used. But occasionally an inverted or horizontal *overscoring* method of use is more preferable. To *overscore* text, the pointer tip is utilized to trace through the linear spaces *above* the text lines while sequentially reading the respective text lines *below* the linear space.

In Fig. 3A, a line of sight (20) is directly before and focused at a page of reading material (21) containing a set of text lines (22) and a set of linear spaces (23). The control member (24) is grasped in the described manner, but is positioned so that it is horizontal and approximately parallel to the surface of a larger piece of reading material (21), with the top end (25) of the control member pointed toward your body. The pointer arm (26) will then be pointing downward and perpendicular to the text lines and linear spaces. A steering elbow and arm (not shown) are then held to the side and moved from the top of the text lines down the page toward your line of sight (20) as the pointer arm is shuttled left and right (arrow-line 28) with a shuttling pointer tip (27) pointing directly down toward one of the linear spaces above one of the text lines to complete the overscoring process of the reading material.

Again, in the above example of reading material set in a flat position before your view, you may prefer to use the tool upright or inverted to underscore the text lines while moving your

The Wave Reading™ Instruction Manual

and read continuously across the text line. In the alternate method, you twist the pointer less smoothly, and less rapidly to allow your mind time to locate word group targets to be seen in single glances. Your mind then *imposes continuity* on what you have gathered in a sequence of glances and provides a continuous stream of meaning for the integrated single glances.

Since both the primary and the alternate method of reading effectively provide the same result of continuity of meaning, each of these two distinct processes may be alternately used as needed during any reading session. Again, during a continuous motion induction process you utilize the Wave tool to induce your eyes to follow the continuous motion of the tool's pointer tip to read across entire lines. During a sequential glance capturing process, you utilize the Wave tool's pointer tip to induce your eye focus to jump from one word group to the next. Your eye focus then continues to move in a hopping or skipping manner across the line as dependent upon where your mind immediately determines it should seize or *capture* a word group in the word sequence of the line.

When you first begin to do this *sequential glance capturing* procedure with the pointer tip, you will notice that your flying eye focus is landing haphazardly in a touch and go process across the text line. As you continue to practice the method, you will realize that your mind is actively seeking to guide your eyes to stopping points which place your eye focus in the middle of phrases and clauses and other word groups which your mind has preconsciously identified as targets.

In other words, your mind is locating and isolating target word groups for you because you have directed yourself to read in this manner. To your inner mind, reading only means to interpret the words of a text in the order in which they were linearly, sequentially presented, whether these words are to be taken in one by one, or in groups. Your mind thus naturally begins to pick and choose what it regards as a *readable* word grouping within its capability for a widened glance, and then proceeds to direct your hand to stop the pointer to help you better focus as you sequentially assimilate the sequential word groups. Each sequentially captured word grouping is then synthesized into a continuous flow of meaning gathered from the ongoing sampling of the word groups.

The purpose of the Wave tool in the alternate sequential glance capturing process is thus to serve as *an intermediate physical agency* for training your mental focus as you progress across text lines of various length. Imaginatively, in the primary method of continuous motion induction, the Wave tool acts somewhat like a waving wand allowing you to read full lines very quickly. Imaginatively, in the sequential glance method, the tool acts like a divining rod for your eye focus as the pointer tip makes its way beneath the text lines.

To reiterate, in the sequential glance capturing process, you utilize your eyes' ability to jump from left to right, along with your mind's ability to isolate word groups which your mind then takes in within a sequential series of widened glances. You utilize the slower movement of the pointer tip not to read continuously through the line, but to act as a focusing point to the middle of successive word groupings targeted and isolated by your mind for a widened glance. Each word grouping is then sequentially synthesized by your mind into a continuous flow of meaning gathered from the continuous sequential capturing motion of your eyes. By making a brief fixation on the word grouping, you *capture* the phrase momentarily and then spring on to the next fixation. That is, you *sequentially capture* each word grouping in a discontinuous manner, which your mind then automatically assembles as the ideas in the text you are reading.

The Wave Reading™ Instruction Manual

When you have trained yourself to properly capture sequential widened glances using the Wave pointer as a guide, it is relatively easy to continue the process without the tool.

To perform sequential glance capturing on shorter lines in half-line segments, the Wave tool is twisted in the manner just described, but the mental pauses that you make are such that they will divide the text as though there were an imaginary line running vertically down the middle of the short line column. The actual act of processing the line will occur as you briefly glance at the word groups on alternate sides of this imaginary centerline. Similarly, with longer lines requiring three or more eye jumps, your mental objective is to imagine as many vertical divisions as you think appropriate for the line length and then attempt to isolate target word groups as possible within those imaginary guidelines. When lines are relatively short (as in newspaper columns), the pointer tip can be positioned in the middle of the line and brought successively downward through the midpoint of the lines. Each line is then successively captured in a widened glance.

An alternate method for reading shorter lines utilizing sequential left-right widened glances is to place the control member horizontally parallel *near* to the text lines with the pointer arm placed in an upward or downward right angle position to the text lines. The extended pointer arm is then utilized to physically divide the shorter text lines down the middle. The tool is then moved downward while you read in left-right glances.

Another alternate method for reading shorter lines is to place the control member in a horizontal position with the pointer arm at a preferred angle, but *out and away* from the middle of the text column. The tool is then rotated downward through the middle of the successive text lines so that the pointer tip points directly beneath and marks off each successive line you are reading with left-right glances.

The Wave tool can also be used in an equivalent method, whether upright, inverted or horizontally, to sequentially point to short text lines you wish to take in with a *single* widened glance. If the tool is upright or inverted, this is accomplished by tilting the tool progressively downward and successively stopping the pointer tip either beneath or to the side of each line to mark off each consecutive line in the text being read. If the tool is being held horizontally, then the tool is twisted as explained above so that the rotating pointer arm marks off each line being read in a single glance.

The tool can also be used to read short lines by using the following alternate method. The control member is placed in an upright or inverted position with the pointer arm at a preferred angle. The pointer arm is then placed in actual or near physical contact with the reading material, and progressively slid down the short line column in a horizontal position parallel to and beneath the text lines to be underscored and read in single widened glances.

To summarize the above section, sequential fixation glances can be induced either by *slowing* the pointer tip to assist the mind in targeting word groups, or by using the pointer arm to divide, or sequentially point to, or underscore consecutive text lines. These alternate widened glance methods may be generally applied whether the tool is being used in an upright, inverted, angled, or horizontal position.

Your preferred use positions of the Wave tool should be initially determined by your line of sight relative to the current angle of the text to be read. Generally, you will prefer to alternate between positions which are the most comfortable for you, as well as the most effective and least obstructive to your line of sight viewing. The choice of preferred positions should also be

The Wave Reading™ Instruction Manual

determined by your ability to utilize tilt, wobble, and arm-elbow angling methods which will minimize downward arm movements. It is also helpful to occasionally switch from one reading technique to another so that your mind does not lose its focus on the reading material when your eyes become tired from one or another positional or eye motion method.

Using a Page Gripper

Many versions of the Wave tool are typically provided with a “page gripper” (4 in Fig. 2) added onto the bottom end of a control member. A page gripper is used for gripping the lead edges of text pages to be turned. A page gripper is either a thick, flattened disk or is formed into a protruding, rounded shape, and is affixed to the bottom end of the control member.

A page gripper at the bottom of the Wave tool is utilized by placing the bottom of the gripper against the approximate top right edge of a right page of written material, such as a book or magazine, which is intended to be turned toward the left. The control member is then pressed downward so that the page gripper frictionally engages the surface material of the page. Simultaneously, the control member is pushed to the left along with the now frictionally connective right page until the right page folds and flips over to its opposite side.

Alternately, on less foldable reading material, the page gripper will only be used to lift the edge of the page away from its underlying page and then be lifted, flipped and pushed into place by a grasping finger of the non-steering hand and pushed into place on the left side of the dividing binder, and then held down on the left side of the book, magazine, etc. In some versions of the Wave tool, the page gripper may be a detachable, thimble-like rubber boot either used with the control member or removable for use with a finger, the purpose of which is to provide friction between a finger's inertial force and the page to be gripped and moved.

The page gripper may also be used in conjunction with a suitable rigid bar, such as a plastic ruler or other flat piece of any material that may be slid downward across the surface of an open book. Such a flat bar is utilized to exert pressure against the binding means of a book to better flatten the pages of reading material, and is controlled by the non-steering hand when using a Wave tool in the methods just described. It is important to flatten your reading material as much as possible in order to allow sufficient room for the pointer arm to operate properly and to avoid erratic eye motions.

Wave ReadWrite Tools

Often when reading it is necessary to take notes or highlight material. Various versions of the Wave tool called Wave ReadWrite tools are made to suit the dual purpose of providing both a twistable pointer and a handwriting instrument. In one version, a clip-on accessory to a pen is provided which clasps the pen barrel at a point opposite the pen's standard compression clip. The accessory has a pivotal pointer arm on a friction hinge which allows the pointer arm to either remain parallel to the side of the pen barrel or to be adjustably angled as needed. The pen barrel then serves as the control member for the dual-purposed device.

In an alternate version of a ReadWrite tool, the control member is also in the standard barrel form of a handwriting instrument such as a ballpoint pen, a pencil, or a highlighter, but the pointer arm is incorporated into the structure of the writing instrument. Figs. 4, 4A, exemplify this dual-purpose device with a typical ballpoint pen body being utilized as a control member.

The Wave Reading™ Instruction Manual

Typically, such a combined device as shown in Figs. 4, 4A has opposing or separated, downwardly disposed, compression clips which are set at 90° from each other. One compression clip is a standard pen clip utilized to clip the pen to a pocket. The other clip acts as a connector between the pointer arm and the control member.

The grasping and operational methods of the ReadWrite Wave tool are the same as stated in the operation of the Wave tool of Fig. 2. To prepare the tool for use, the pointer arm, if in a storage position, is rotated on its connector pin from its pointer tip retaining hole (if present), and rotated outward to a preferred angle where it is typically held by the spring compression of its compressive clip.

In order to shift from a reading position to a writing position utilizing the ReadWrite tool, the control member grasping brace is shifted to a typical triangulated writing brace. When the writing process is completed, the triangulated writing brace is manipulated back to the control member grasping brace. When the tool is used as a writing instrument while the pointer arm is in a storage position, the pointer arm is rotated to a position between the thumb and index finger so that the pointer arm will not interfere with the triangulated writing brace.

General Reading Advice

The following reading recommendations are concerned both with the use of the Wave tool and with common sense approaches to reading in general. The advice covers some of the physical difficulties involved in the act of reading, and then covers some of the mental aspects of reading which we all face at one time or another. If you think anything here may apply to your current reading circumstances, consider using the information to your advantage.

When extending your steering arm toward your reading material, occasionally allow the back of your upper steering arm to rest against your body as you manipulate the Wave tool. If you are reading from a computer monitor, occasionally fold your opposite arm against your body and rest the back of your upper steering arm against the back of your opposite wrist. Reading while using the tool on a computer monitor is more difficult because of the glare and the need to scroll the text. It will help speed things along if use a scroll wheel, or use the Page Up and Page Down command buttons to position your text more quickly. In some instances you may find that moving the pointer arm of the tool across the text is causing a strobe effect. Increasing your monitor's refresh rate, and/or slowing the twist rate of the Wave tool will significantly reduce any strobe effect that you might otherwise encounter.

Try to avoid moving your head back and forth as you use the Wave tool: *Just move your eyes*. When you first begin to utilize the Wave tool to read by means of the various Wave reading methods, you may find that your eyes are having difficulty following the pointer through its successive sweeps. Since you are probably using eye muscle positions and actions to which you are unaccustomed, do not force the issue. Take frequent breaks to avoid eye strain. Look away into the distance to refocus your eyes. Roll your eyes around to stretch and relax your eye muscles. Stretch and walk for a few minutes. If your eyes become tired while reading, or if you feel the tension in your eye muscles increasing, pause to close your eyes and gently massage them. Let your eyes rest while closed for a moment and then open them. Relax yourself and then

The Wave Reading™ Instruction Manual

begin anew. To help reduce eye fatigue, frequently switch back and forth between reading methods.

Adjust your body position to allow for clear lines of sight toward your reading material. Be sure your head is not tilted or turned excessively to view the material. Orientate the material to an appropriate angle to avoid reflective glare. Use a posture which is comfortable, but supportive to your upper torso and neck. Frequently flex and stretch different muscles groups to avoid nerve and muscle fatigue. Adjust your position in your seat to support your lower back and frequently stretch and move your lower back muscles to avoid becoming stiff and achy.

To prevent neck and shoulder muscle fatigue, occasionally change your line of sight. As you use the Wave tool be sure you are not tilting your wrist excessively. Move your head from the front of the text to the right and left while continuing to read with the tool. If your steering hand or fingers become fatigued, switch to your other hand to use the tool. The twisting motion involved is easily adapted to opposite handedness.

If you find yourself becoming stressed, bored or tired and have no time to take a break, pause the pointer tip occasionally to allow your mind to better catch up to your eye motion processing rate. If you have lost the continuity of the story, account, or explanation of whatever you are reading, backtrack and re-read the misunderstood passages until the meaning of the text is clear. If you still have not gathered meaning from what you just reread, *leave it* and return to it again when you are less distracted or tired. Slow down or pause to regain focus whenever you sense that you are losing connection with and continuity within the material.

In order to avoid equating assigned reading with negative feelings such as dread, boredom, anger, and so on, it is often necessary to induce a positive attitude toward what you will be reading. With practice it is easily possible to induce a sense of curiosity, interest, and anticipation to what the assigned reading will bring as a gain to your life. When interest is increased, comprehension and recollection are greatly improved. By speeding up the reading and perception process, the Wave tool will make it less likely that you will dread or be bored by what you read. Most negative feelings about assigned reading arrive when the reading process is anticipated to be slow and tedious, and without apparent purpose. To become more focused on your reading material, try and anticipate what you will be learning when you read the material. Become curious about what you do not yet know. Imagine that it will interesting and pleasurable to know the answers to the questions raised by the title, chapter titles, and various pictures or diagrams included with the material, if any. Ask yourself what kind of information you might expect to acquire in reading the selection? Later ask yourself if that is what you found therein. If you cannot find a way to take pleasure in what you are reading, but must read it, then attempt to scan through the text until you have found what you must have and leave the material. Reading should be an exciting and pleasurable experience, even if its sole purpose is to gather information that you are obligated to acquire.

It is helpful to understanding if you begin your confrontation with all new reading material by previewing its contents, i.e. by scanning through it quickly to obtain a general understanding of what the material covers and asking yourself what the purpose of the material

The Wave Reading™ Instruction Manual

might be. This practice of sampling a text by noting its various headings and key words and asking yourself leading, goal-orientated questions about the material will help set a general backdrop of receptiveness and inquisitiveness to what you are about to read. It will help you to establish some sense of purpose for what you are about to read, whether that purpose is simply to seek enjoyment from reading a story, or to search for needed information.

Your comprehension and retention of what you read will generally increase as you read faster simply because you will have covered more material in a briefer time and so processed it internally as a summarization. Comprehension allows you to understand and utilize the material now. Retention allows you to keep the information in your long-term memory so that you may recover it for future conscious use and application.

Whether or not you retain the important points of what you read will depend first and foremost on how well you experience and understand the material as you *hear* it. Retention and comprehension are aspects of the same mental processes. What you have experienced within as having been graphically imaged and experienced with *expressive feeling* will endure in your mind far longer than material wherein you have only heard the words.

To better retain your reading material, frequently take thoughtful pauses wherein you mentally review what you have read to summarize it to yourself and to realize its contribution to what may have preceded it. If you find that you cannot recall the main points of what you have read, scan the material again to seek out the key points to refresh your memory. If you find that you still cannot remember the key points, take notes about the key points of the material for later review.

Try to impose a ban on thinking about issues unrelated to what you are reading. Thinking about, or imagining the meaning of the material you are reading is the reason you read the material. Whereas it is possible to multitask and read and think about other issues at the same time, it is less confusing to your brain processes if you allow a specific time for reading a line, a paragraph or even a chapter, and then allow a specific time to think about unrelated issues. Try to realize when your thinking is purposeful to your reading and when it has shifted away from the topics and themes of the text. When you choose to think about other issues, stop reading until you can again clarify what you are reading.

When you pause to think about what you have just read, for example, between a series of paragraphs, reflect momentarily on the basic questions of all text: Who, what, when, where, why, and how. Who did you read about? What were their actions? When did it occur? Where did it occur? Why did these actions occur? How did they occur? What is the meaning of what you read? What is the purpose of what you read? And so on.

When you are in the process of rapid reading you should not be proactively thinking, but only *reactively* thinking, i.e. reactively listening to form images and feelings, but not to attempt to solve problems. You choose to read faster so that you may gather more information in less time, i.e. *to listen faster*. When you wish to actively think about what you have heard you should *stop* the listening process and again consider: who, what, when, where, why, and how? When your mind is clear, begin to read again.

You read so that you may receptively gather meaning or information that you can either immediately enjoy or utilize after reading. Thus as your mind wanders to actively think about personal issues, business issues or other issues, it is time to stop reading and complete your

The Wave Reading™ Instruction Manual

active thinking either by taking an action or making a note to later take action. When you return to reading, resume your reactive state of listening to the flow of the text.

Rapid reading is not for all types of material. Your reading rate should thus be continuously adjusted to be appropriate for the type of material you are currently reading. Often you must read instructions and other complex material which require a slower and more precise understanding. Make frequent pauses to be certain that you have a clear understanding of what you are reading. If portions of the difficult material are in fact general information, your rate can be accelerated momentarily, and then adjusted downwards as you again encounter more complex material.

Some reading material may be covered simply by scanning (skimming through) it once or twice to seek out key words which will indicate to you an interesting point that you may wish to read more about at a slow or high rate. When you scan to preview material, the scanning process may be done at a high rate in a zigzag manner of eye movement. Since you are only seeking out words and phrases of interest to you, it is irrelevant that at times your eyes are moving backwards and downward across blocks of text lines.

To make your sight reading/listening experience more effective you should consider the environment in which you are reading. Consider your ambient sound level, lighting, and your options for comfortably orientating your reading material. Since the sound level in your mind is more or less at a constant natural level, it cannot be effectively turned up like an electronic voice. But when the surrounds are blocked out or neutralized, the relative sound level in your mind will seem much louder and more clear. If you cannot avoid distracting background noises consider using ear plugs, or using earphones which are connected to non-distracting instrumental music. Similarly, you should consider your lighting circumstances and try using a light source that is sufficient to illuminate your reading material without glare.

Try to stay attentive and focused on hearing the word flow and thought stream of the text. As you begin to use the Wave method, the tool will help you to focus on what is being read partially because it involves a conscious interactive physical process, i.e. the act of moving the pointer and allowing your eye motion to follow it accordingly. Focus as well on the expected mental reading process, i.e. the act of hearing and perceiving meaning in the word flow. As your experience with the Wave tool continues, you will realize that your mind and eyes will anticipate the continuous nature of the pointer movements. At this point you should attempt to read your text in the method of the pointer tool, but without using the tool until you again need it to induce the continuity of eye movement, as well as controlled stopping and starting. As you continue here, bear in mind that your goal in the use of the tool is to do without the tool as much as possible.

When you think you have come as far as you will go in the use of the tool and have thus found your sought for comfortable reading rates for various levels of reading difficulty, try reading How-to books about reading to find other reading, study, and memory strategies. Change your old routines as you find new and better ones. Try to develop a passion for reading and a continuous curiosity for the yet unknown. You have a new and powerful tool now to help you point your way in your battle against ignorance and apathy.

All you have to do is use it.

The Wave Reading™ Instruction Manual

Possible Pitfalls

The goal of your reading should be to understand what you read. With sufficient practice you can train your mind to consistently follow the meaning in the word flow that you are sight reading and hearing. But initially, your mind, not being accustomed to the intrusive rate at which ideas and feelings are flowing through it, may draw back, rebel, and perhaps initially falter at this higher rate of processing.

Your reading rate, even when properly adjusted for the material you are reading, will depend upon many factors, not the least of which is your eyesight, your overall health, your immediate attitude toward the reading process, and so on. All of these various factors may serve to inhibit your perceptual reaction time, or cause you to need to vocalize the words you are reading, or otherwise affect and impede your eye motion rhythms.

You may find yourself regressing into a loss of attention and eye focus, and find your mind wandering and unnecessarily re-reading passages you have already read and not truly perceived. You may be trying to memorize everything you have read rather than attempting to just recall the truly important points. Forced acceleration of reading by using the induction methods of the Wave tool may not be a good idea at these times.

A better idea might be to wait until your overall condition has improved or until your ability to read is better developed through special reading programs available in many education centers. You can only induce yourself to read faster using the Wave tool if you already know how to read well in the language you are reading. The tool cannot teach you to read better. It can only accelerate the reading rate that your innate abilities allow by improving your eye motion and allowing you to take advantage of the various techniques suggested thus far. It is more important to read better than it is to read faster. To read better, you must increase your vocabulary and utilize a dictionary when you are truly unclear as to the meaning of a word in context.

And if you face and overcome each pitfall as it arrives and actually do learn to use the Wave methods to increase your reading speed and comprehension abilities? What will change?
You will change.

Wave Reading as a Growth Experience

Imagine if you will, that for a very long time you have been using a computer that is slow by state of the art standards. You then acquire a new computer that is incredibly rapid in comparison. In a similar way, as your reading skills increase it may seem as though you have upgraded your entire mental system and have become to some extent a different person in the process. You should be prepared for that eventuality.

The person you will become will be more focused and more able to concentrate on the written word as though it were an adjustable informational record which can either be heard slowly and methodically, or rapidly, but clearly, or even paused momentarily as you loop over material for clarification of whatever meaning it may hold for you.

As noted earlier in this manual, in time you will know your limits in this process. You will eventually reach an upper limit rate of rapid reading which is both comfortable for you and yet far beyond your current rate of interpreting, comprehending and retaining the written word.

The Wave Reading™ Instruction Manual

To learn to read in this way is to change the way in which you read. It is to find the middle way between opposite extremes. Like the string of a musical instrument, if a line is read too tightly it will snap into an unreadable blur of broken parts. And if it is read too slowly, it will not properly play. But when it is properly, comfortably tuned to your mind, it will play quickly and smoothly, and all of the note words of the line will be heard as reverberating meaning.

Whether you eventually learn to do without the Wave tool, or use it to initiate your reading sessions, or if you use it continuously, the Wave tool will always be there to serve your reading needs. *All you need to do is use it.*

A Few Key Points to Remember

- Allow your eyes to sweep, or *wave* smoothly and continuously across an entire line of words, rapidly taking in the words as a single flow to which you are attentively *listening*. Or use the Wave tool to induce your mind into a process of sequential glance capturing.
- Make your return sweep, or *wave* smoothly and continuously without snapping the pointer to its initial alignment position for reading the next line.
- Maintain continuity between successive lines to allow your mind to rapidly assimilate and integrate one line with another.
- Try to maintain a steady tempo throughout your reading, but continuously adjust your rate to the material you are reading.
- If you do not understand a line or lines you have read, *reread them*.
- Read and *listen* within with *feeling*. *Hear* the necessary expression that the writer as the speaker of the text would use to captivate an audience.
- Maintain your calmness and curiosity as you read, and try to anticipate where the text is taking you.
- If one pointer technique is not working for you, try another.
- Try as often as possible to duplicate the eye motions the Wave tool induces and read without it.

The Wave Reading™ Instruction Manual



Fig. 1

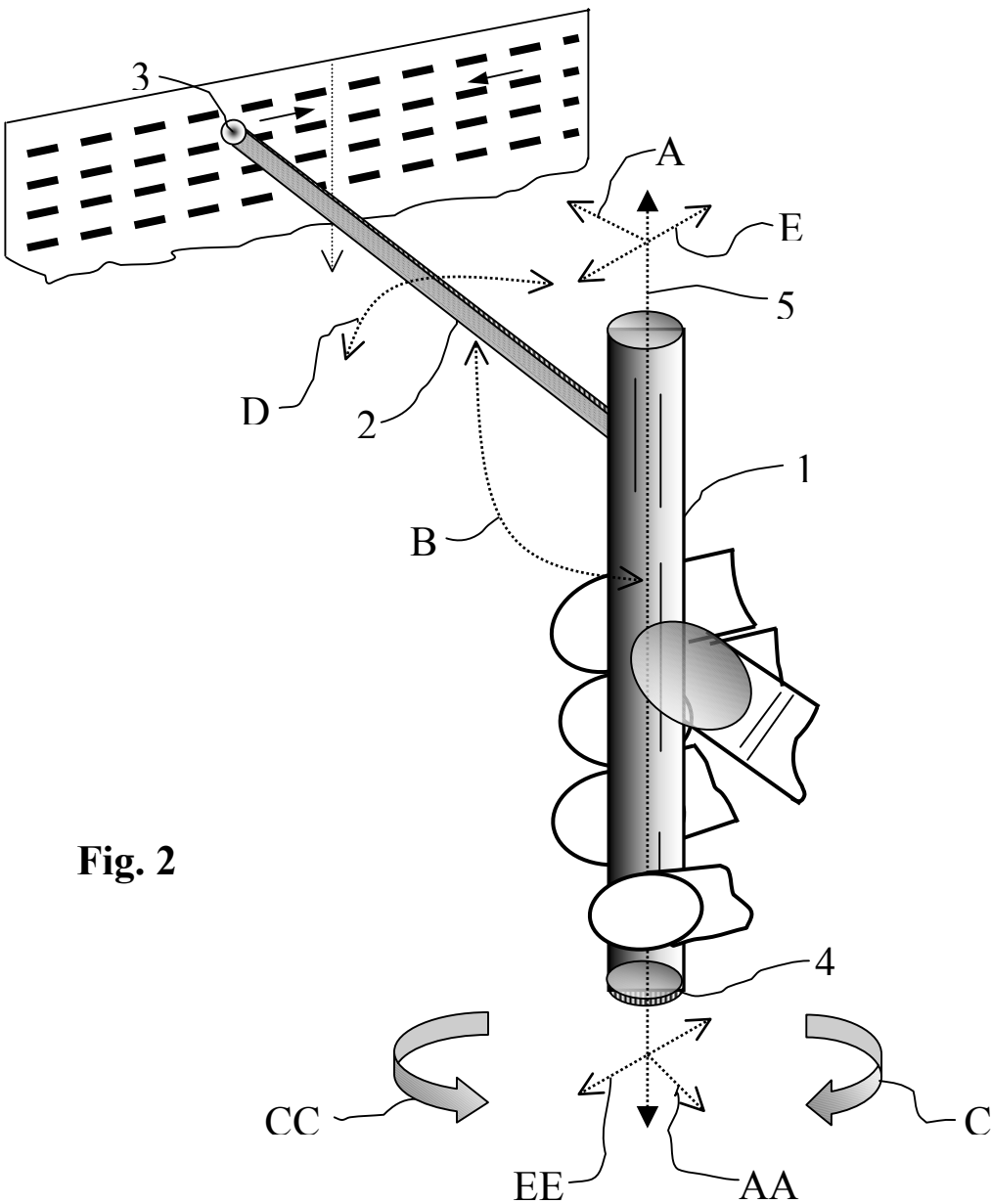

Fig. 2

The Wave Reading™ Instruction Manual

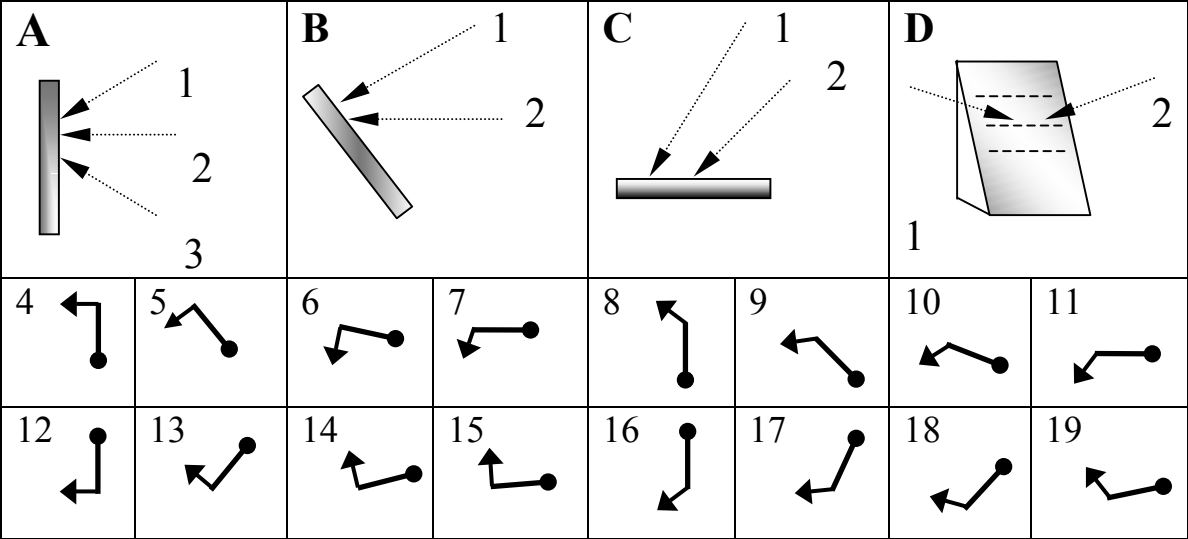

Fig. 3

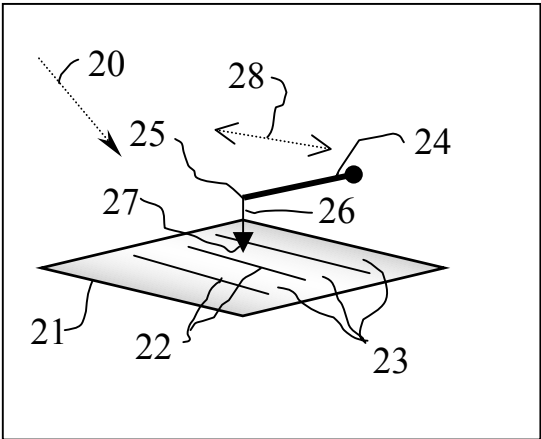

Fig. 3A

The Wave Reading™ Instruction Manual

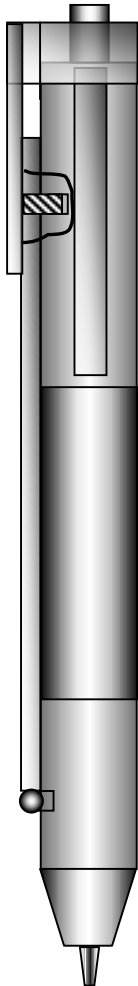

Fig. 4

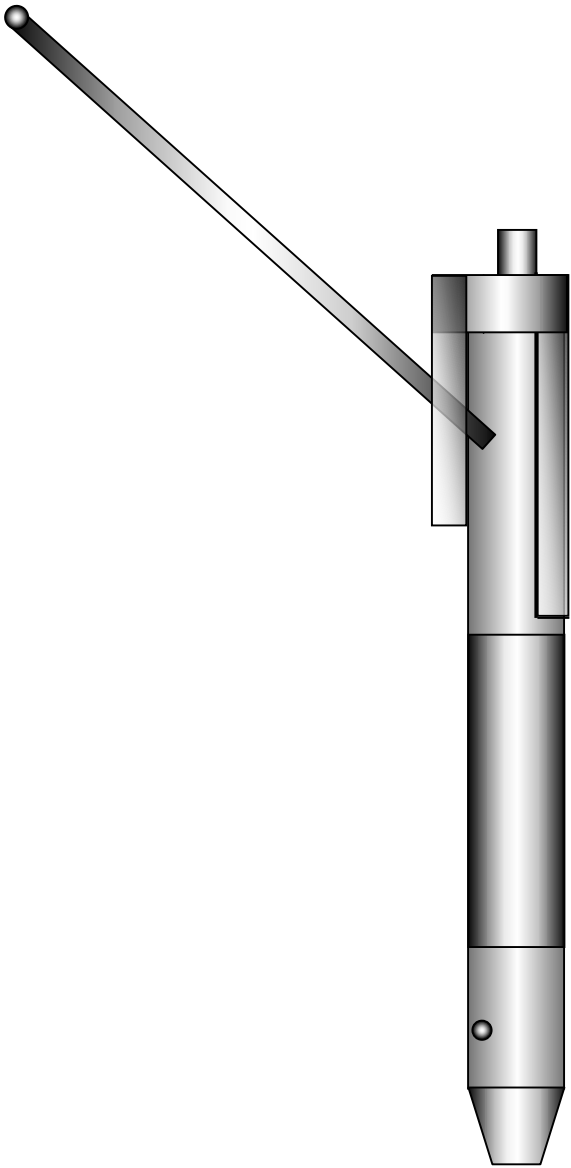

Fig. 4A